

PROMOTOR CAST IRON MOTORS

THREE PHASE INDUCTION MOTORS TYPE Y3/YX3

- MOUNTING & MAINTENANCE -

TABLE OF CONTENTS

page

| | | |
|----|---|---|
| 1 | General information | 2 |
| 2 | Delivery | 2 |
| 3 | Mounting | 2 |
| 4 | Coupling | 2 |
| | 4.1. Direct coupling | 2 |
| | 4.2. Indirect coup | 3 |
| | 4.2.1. Flat belt or V belt | 3 |
| | 4.2.2. Spur gear transmission | 3 |
| | 4.3. Shaft couplings | 3 |
| 5 | Electrical connections | 4 |
| | 5.1. General information | 4 |
| | 5.2. Circuit detail | 4 |
| 6 | Putting into service | 5 |
| 7 | Maintenance | 5 |
| | 7.1 Dust | 5 |
| | 7.2 Moisture | 5 |
| | 7.3 Wear & vibrations | 5 |
| | 7.4 Greasing | 6 |
| | 7.5 Replacement of ball or roller bearing | 6 |
| 8 | Bearing types and inner diameter of bearing | 7 |
| 9 | Grease-interval Bearings | 8 |
| 10 | Motor spare part list / drawing | 9 |

PROMOTOR CAST IRON MOTORS

1. GENERAL INFORMATION

This manual concerns normal three phase induction motors with an output varying from small to middle size; they are externally cooled, totally enclosed, supplied in a cast iron frame and provided with ball bearings or roller bearings lubricated with grease.

2. DELIVERY

After receipt, remove the package material if any and mind the parts that have been delivered loose. In the case of unpacked motors, the glands are often put in the terminal box to protect them against damage.

Check the motor to see whether transport damage has occurred.
You should be able to rotate the shaft easily and smoothly with the hand.

Compare the details on the rating plate with those of the power network and with the requirements of the motor.

3. MOUNTING

The motor must be fixed on a stable, clean and flat foundation with good fitting foundation bolts, using washers.

Never mount a motor manufactured for a horizontal mounting on a surface with an angle of inclination of more than 15 degrees without consulting the supplier in advance.

Foot & flange motors always have to be mounted in such a way that the drain holes, if any, are situated at the bottom, otherwise you run the risk that moisture has condensed into the motor and cannot be drained off. To this end you need to remove the drain plugs.

Under no circumstance must the free flow of air be obstructed to the cooling fan or the motor will overheat.

This has also to be borne in mind when you are mounting motors in enclosed spaces of small size.

The ambient temperature must not exceed 40 degrees centigrade, unless otherwise agreed upon at the time of ordering.

4. COUPLING

4.1 Direct coupling

The motor and driven shafts must be accurately aligned. In case of a flexible coupling, the manufacturers distance between the parts to be coupled must be adhered to, also the degree of misalignment must be within the makers tolerance. We do not recommend using solid couplings.

PROMOTOR CAST IRON MOTORS

4.2 Indirect coupling

4.2.1. Flat or V Belts

Mount the motor on slide rails in order to adjust belt tension.

The belt pulley has to be fitted hard up the shoulder of the shaft. The pulley center line should be within the shaft center line. Use correctly sized belts with a correct profile and in sufficient numbers to drive without slip and undue tension. Align both pulleys accurately in such a way that the center of both pulleys are in line.

Multi V belt drives need to be matched sets.

A belt pulley, which is either too small or too wide, or too high, a tension on the belt may damage the bearing or cause a shaft break.

In case of doubt, consult the supplier.

4.2.2. Spur Gear Drives

The motor and the driven machine have to be positioned in such a way that the two gears mesh correctly. The motor should then be fixed with dowels.

4.3. Shaft couplings and pulleys etc.

Remove the corrosion protection from the shaft extension and the coupling elements. The coupling parts, belt pulleys and gear wheels need to be dynamically balanced and fit easily on the shaft and to be provided with good fitting keyway.

In the factory the rotor has already been dynamically balanced including a half key in the shaft.

The dimension and the tolerances of the shaft extension and the key are indicated on the motor dimension sheet.

Assembling the coupling elements has to be done with great care. Careless handling may damage the bearings, shaft or end shields.

Do not file or emery the shaft to achieve a fit!

When fitting pulleys couplings or bearings, we recommend using heat to elements; therefore the part to be mounted has to be heated till ± 80 degrees above the ambient temperature.

A large washer and set screw can be useful for pushing on pulleys using the tapped hole in the shaft. Only use proper tools for removing the above mentioned parts e.g. pulley drawers.

PROMOTOR CAST IRON MOTORS

5. ELECTRICAL CONNECTION

5.1. General information

On delivery the motor will rotate clockwise looking at the drive when the phases L1, L2 and L3 are connected respectively to the connection terminals U1, U2 and U3.

Exchanging any two-phase lines can change the direction of rotation. When a motor is only suited for one direction of rotation, it is indicated with an arrow on the motor fan cowl.

Connecting cables must conform to IEE regulations, as must earthing requirements.

Line fuses only protect the cables in case of short-circuiting and do not constitute a safeguard against the overheating of the winding caused by overload. Therefore it is recommended that a motor starter and overload is fitted, giving single phasing and overload protection.

5.2. Circuit

Normally our motors are provided with a terminal box with six connections, to which six leads from the winding are connected either in a delta connection or in a star connection by means of connection links.

Usually two voltages are indicated on the rating-plate of these motors, which means that the motor can be connected to a circuit having one of these voltages.

If the mains voltage is corresponding with the lowest indicated voltage, the winding has to be connected in delta connection (see figure 1); if it is corresponding with the highest indicated voltage, the winding has to be connected in star connection (see figure 2).

A motor with e.g. 230/400 V on its rating-plate is suited to be switched on directly, on a circuit with a voltage of 230 V between phases with the winding connected in a delta connection, or on a circuit with a voltage of 400 V with the winding connected in a star connection.

But if the motor is switched on with a star-delta starter the motor is only suited for a mains voltage on the rating-plate, this is the delta voltage. In this case, the connection strips on the terminal box have to be removed when the motor is connected; the star and delta connection will be made successively in the starter during the run up.

If only one voltage is indicated on the rating-plate together with the delta sign, the motor can be switched on directly at the indicated voltage or with a star/delta starter.

Pole change motors (for two or more speeds) are connected according to a diagram sent together with the motor.

PROMOTOR CAST IRON MOTORS

6. PUTTING INTO SERVICE

Before putting a motor into service, one should check especially when the motor has not been used for a long time that the insulation resistance of the winding is sufficient. The insulation resistance has to be at least 10 meg/ohms on a 1000V megger.

If the insulation resistance is not high enough, the motor has to be dried out and revarnished or rewound.

Check all connections and adjust the thermal protection units to the correct current. Switch the motor on in a no load state to determine the direction of rotation. Load the motor gradually and check whether it runs without vibration.

The motor can be used under deviation of the main voltage $\pm 5\%$ or frequency of max. $\pm 2\%$ compared to the nominal frequency or nominal voltage, in compliance with the international regulations for electric machines.

7. MAINTENANCE

The totally enclosed and fan cooled three phase squirrel cage induction motors require very little maintenance.

Nevertheless it is recommended to check the motor regularly in order to prevent a breakdown caused by dust, moisture, vibrations, too much or too little greasing.

7.1. Dust

The outer parts of the totally enclosed motors, especially the cooling ribs or cooling channels, have to be kept as clean as possible in order not to obstruct the cooling air from the fan extracting the heat from the motor frame.

7.2. Moisture

Motors, which are not often run, should be started from time to time to prevent moisture affecting the windings in the long term.

7.3. Wear & vibration

To prevent abnormal wear & vibration, one should:

- a. take care that the tension of the belt or the chain is not too high;
- b. check whether the mounting of directly coupled machines is correct;
- c. Check whether the foundation bolts the bolts to fasten the motor and the slide rails are tight.

PROMOTOR CAST IRON MOTORS

7.4. Greasing

Before they leave the factory, the bearings of the HUALI Motors are filled with a high quality Lithium base grease.

The sizes 80 up to and including 132 are provided with shielded/sealed bearings (ZZ-C3), witch have been filled with life-time grease by the manufacture of the bearings.

Motors with sealed bearings and no re-lubrication system require no maintenance other than checking for noise & temperature during their lifetime.

Sizes 225 up to and including 400, has been provided with a permanent lubrication system containing a grease valve.

The lubrication must take place when the machine is running.

The old grease is ejected from the grease valve thus maintaining the correct level and avoiding overfilling which would be harmful.

7.5. Replacement of ball or roller-bearings

When a bearing has to be replaced, the old bearing has to be removed from the shaft with proper tools in order not to damage the shaft. Thereupon the bearing location on the shaft has to be cleaned and checked thoroughly.

To fit a new bearing correctly, heat to 80 – 90 degrees centigrade with an electric induction heater, then slip quickly onto the shaft up to the stop. In the case of a roller bearing only fit the inner race in this manner.

A suitable sleeve may be used to help by tapping gently to seat the bearing home. Note that under no circumstances must a bearing be driven home cold with excess force. We must also stress that pressure must not be applied to the outer race of a ball bearing.

Do not mount the end shield until the bearing has cooled down.

PROMOTOR CAST IRON MOTORS

8. Bearing type and bearing inside diameter

| Huali Motor type | Poles | type of bearing | | Bearing inside diameter(mm) |
|------------------|---------|-----------------|----------------|-----------------------------|
| | | Driven end | Non Driven end | |
| Y3-80 | 2/4/6/8 | 6204 ZZ C3 | 6204 ZZ C3 | 20/20 |
| Y3-90 | 2/4/6/8 | 6205 ZZ C3 | 6205 ZZ C3 | 25/25 |
| Y3-100 | 2/4/6/8 | 6206 ZZ C3 | 6206 ZZ C3 | 30/30 |
| Y3-112 | 2/4/6/8 | 6306 ZZ C3 | 6306 ZZ C3 | 30/30 |
| Y3-132 | 2/4/6/8 | 6308 ZZ C3 | 6308 ZZ C3 | 40/40 |
| Y3-160 | 2/4/6/8 | 6309 C3 | 6309 C3 | 45/45 |
| Y3-180 | 2/4/6/8 | 6311 C3 | 6311 C3 | 55/55 |
| Y3-200 | 2/4/6/8 | 6312 C3 | 6312 C3 | 60/60 |
| Y3-225 | 2/4/6/8 | 6313 C3 | 6313 C3 | 65/65 |
| Y3-250 | 2/4/6/8 | 6314 C3 | 6314 C3 | 70/70 |
| Y3-280 | 2 | 6314 C3 | 6314 C3 | 70/70 |
| Y3-280 | 4/6/8 | 6317 C3 | 6317 C3 | 85/85 |
| Y3-315 | 2 | 6316 C3 | 6316 C3 | 80/80 |
| Y3-315 | 4/6/8 | N319 | 6319 C3 | 95/95 |
| Y3- 355 | 2 | 6319 C3 | 6319 C3 | 95/95 |
| Y3- 355 | 4/6/8 | N322 | 6322C3 | 110/100 |

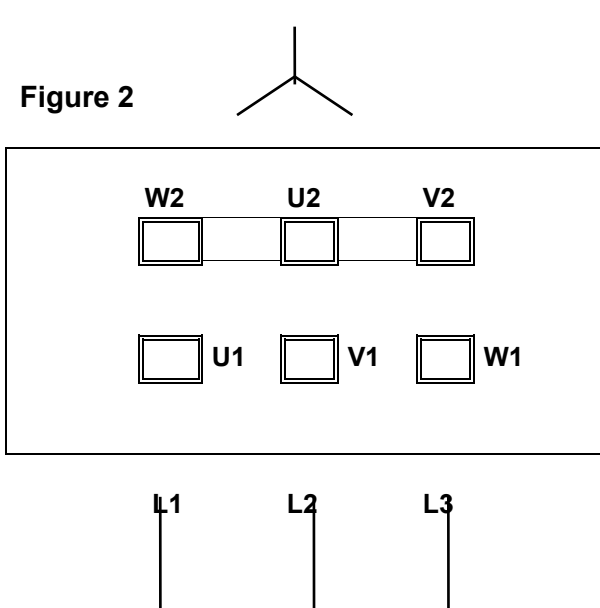
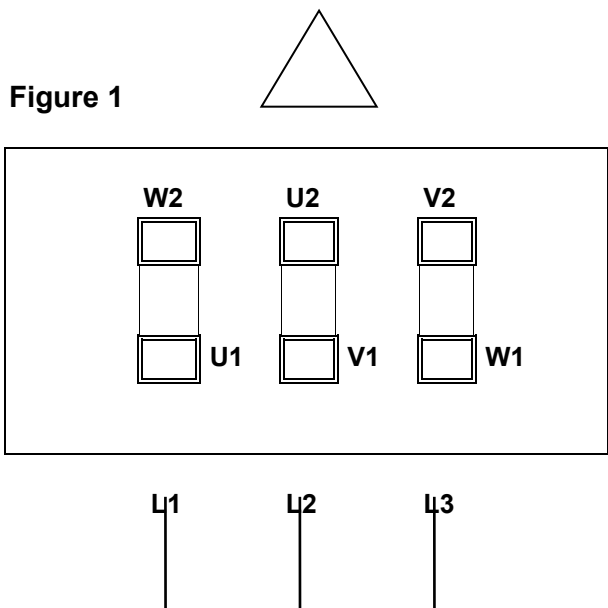

PROMOTOR CAST IRON MOTORS

9 Grease-interval Bearings

By the term “greasing interval” we mean the number of working hours after which the bearing lubricant has to be replaced.

Electric motors have such a wide range of application that they must cope with many adverse conditions as for instance dust, moisture, vibration, temperature, chemicals, marine atmosphere and of course, the mounting position and loading of the driven machine.

Generally we can say lubrication life is a product of time, speed and the bearing size. Due to the impact of all these factors, it is practically impossible to determine any exact values that are valid under all circumstances.

Nevertheless it is necessary to provide at least some guidelines concerning greasing to the user.

Under normal load and environmental conditions the quality of the grease ensures proper operation of the motor for about 10000 service hours with 2-pole designs and 20000 service hours with multi pole designs. If not otherwise agreed upon the grease need not be refilled during this period. Nevertheless the condition of the grease filling should be occasionally checked also within the said lubricating intervals.

The stated service hours are only current under operation with rated speed. For relubrication thoroughly clean the bearings with a suitable solvent and use the same or substitute grades specified by the motor manufacturer. Bear in mind, however, that the bearings should be filled only up to about 2/3 of their free space as a complete filling of the bearings and bearing covers results in an increased bearing temperature and therefore in increased wear. For bearings with relubricating facility regrease at the grease fitting with the motor running according to the grease amount required for the motor in case. The relubrication intervals should be looked up in the following table:

A chemically aggressive environment, extreme moistness, strong vibrations, high or low ambient temperatures are not normal circumstances and such conditions must be taken into account.

| Construction size | Two pole motors | Four-pole and multi-pole motors |
|----------------------------|-----------------|---------------------------------|
| 80 up to and including 355 | 2 000 hours | 4 000 hours |

PROMOTOR CAST IRON MOTORS

10 Motor spare part list / drawing

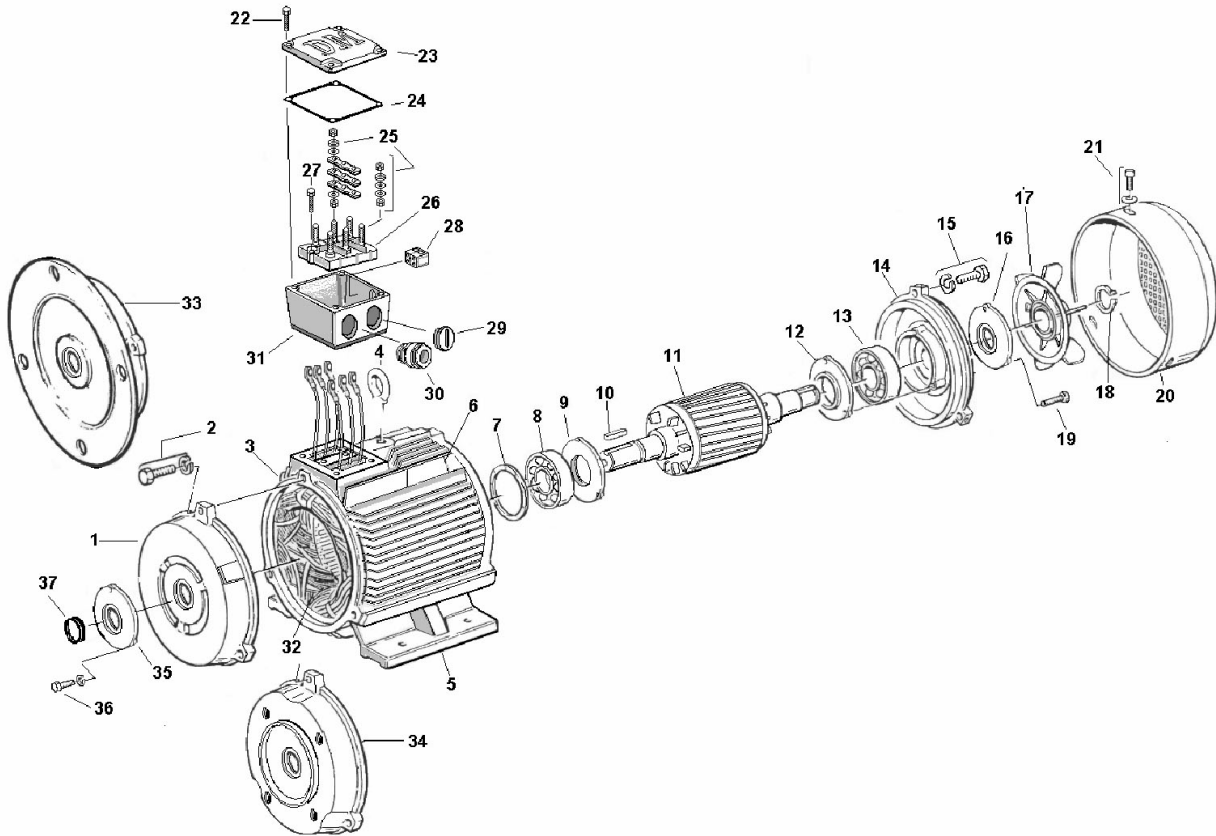

LIST OF SPARE PARTS

Three-phase motor with squirrel-cage rotor

- | | |
|--|------------------------------------|
| 1 Shield B3 DE | 19 Bolt bearing cap NDE |
| 2 Fixing bolt shield DE | 20 Fan cover |
| 3 Stator frame | 21 Fan cover screw |
| 4 Eye bolt | 22 Terminal box screw |
| 5 Feet | 23 Terminal box cover |
| 6 Nameplate | 24 Terminal box gasket |
| 7 Spring washer | 25 Connection fixation nuts |
| 8 Bearing DE | 26 Terminal board |
| 9 Inner Bearing cap DE from size 180 | 27 Terminal board holder bolt |
| 10 Key | 28 Terminal block PTC |
| 11 Rotor core | 29 Blinder |
| 12 Inner bearing cap NDE from size 180 | 30 Cable gland (not standard) |
| 13 Bearing NDE | 31 Terminal box house |
| 14 Shield NDE | 32 Windings |
| 15 Fixing bolt shield NDE | 33 Flange B5 |
| 16 Outer bearing cap NDE from size 180 | 34 Flange B14 |
| 17 Fan | 35 Bearing cap DE outside |
| 18 Circlip | 36 Fixing bolt bearing cap outside |